

PRO - AV

HI-END
SERIES



HIGH-END DIGITAL SIGNAGE SYSTEM



Why choose ANGUSTOS Pro-AV ?

We can provide you the best solution that suits your TVs, interactive screens, meeting room high-end projector, digital signage and videowall system. We do not just simply sell the equipments but also a smart solution that is just as well designed as it is functional. Solutions that guarantee and define our brand:

- Ease-of-use
- Design
- Innovation
- Reliability
- Ease-of-installation.

To help you find the exact solution you need, Angustos has an extensive product range that is possible to compose a solution for nearly every Pro AV application. Our highly skill solution teams are happy to help you to quickly find the best solution for your installation, saving you the time and effort and hassle for complex system.



ANGUSTOS PRO AV APPLICATIONS

- Media - Telecom - Broadcast
- Education - Training
- Manufacturing - Quality Control
- Retail - Advertising
- Meeting Room - Conference
- Healthcare visual system
- Entertainment
- Government - Control Room



HDMI KVM Extender Over IP - 100 meter with Video Wall Model : AHVE-CBH265

FEATURES

- Easy to create project, control and manage the system
- HTTPS, SSH security compatible
- Built-in Web GUI / supporting Drag & Drop operations
- Video (with preview), Audio, RS-232, IR, KVM control
- Dual network ports (POE function) with Multicast Control.
- LAN/RS-232 port control with third-party support.
- IR signal receiving (3.5mm jack, 12V level)
- Multiple circuits protection, lightning protection and ESD design
- Support 24/7 operation.



*Work with AHVE-HU10Wi

PACKAGE CONTENT

- *Video Over IP Control unit x 1
- *Phoenix connector x 2
- *Power Adapter x 1

TCP/IP **FULL HD 1080P** 100M

SPECIFICATION

Operating Temperature	-10° to 45°C
Operating Humidity	0 to 90%RH
Control	1 x RJ-45 (100M) 1 x IR (3.5mm) 1 x Digital I/O 1 x RS-232
Resolution Support	1920x1080p @60Hz
HDCP Compliance	HDCP 1.2 / 1.4
HDMI Compliance	HDMI1.3, 8-12 bit color

Distance UTP / Bandwidth	100m / 100M
Impedance / ESD	100 Ω / ±4kV - ±8kV
Control I/O	6 pin Phoenix
RS-232 I/O	3 pin Phoenix
UTP LAN (POE)	Video LAN port
Power consumption	~4.5 W
Power adapter	DC 12V / 1A
Size (mm)	204 x 98.5 x 21.5

CONNECTION DIAGRAM

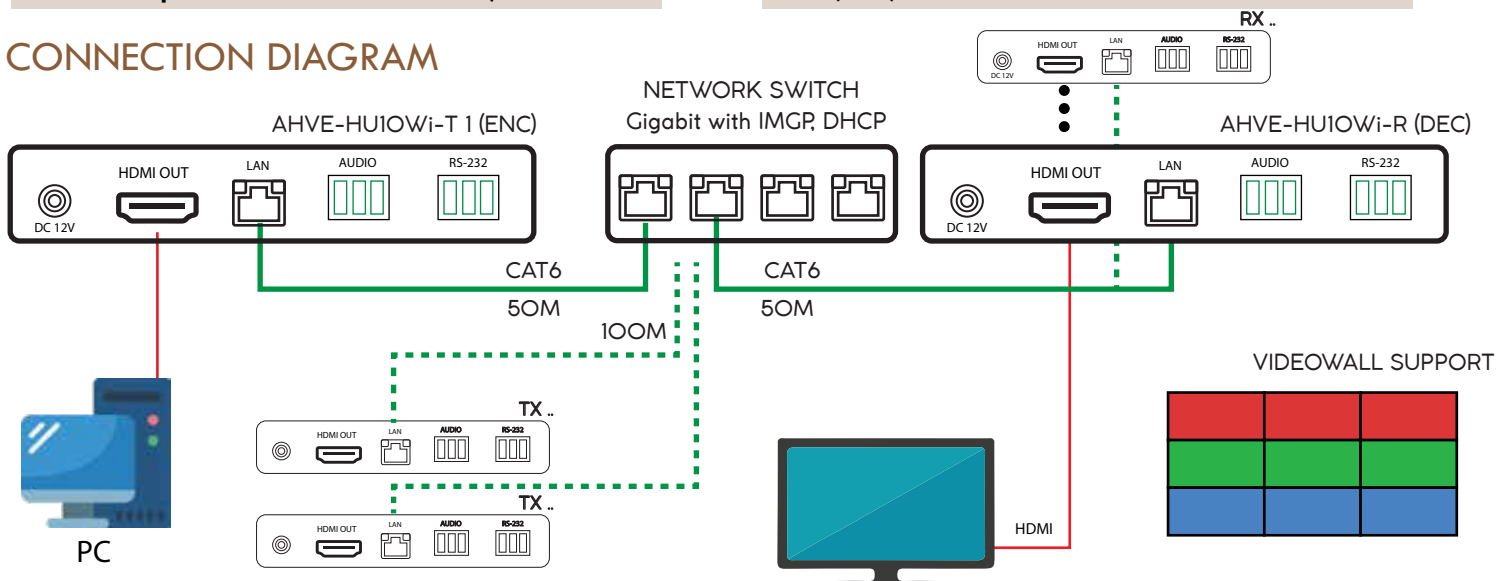

HDMI KVM Extender Over IP - 100 meter with Video Wall Model : AHVE-CBH265

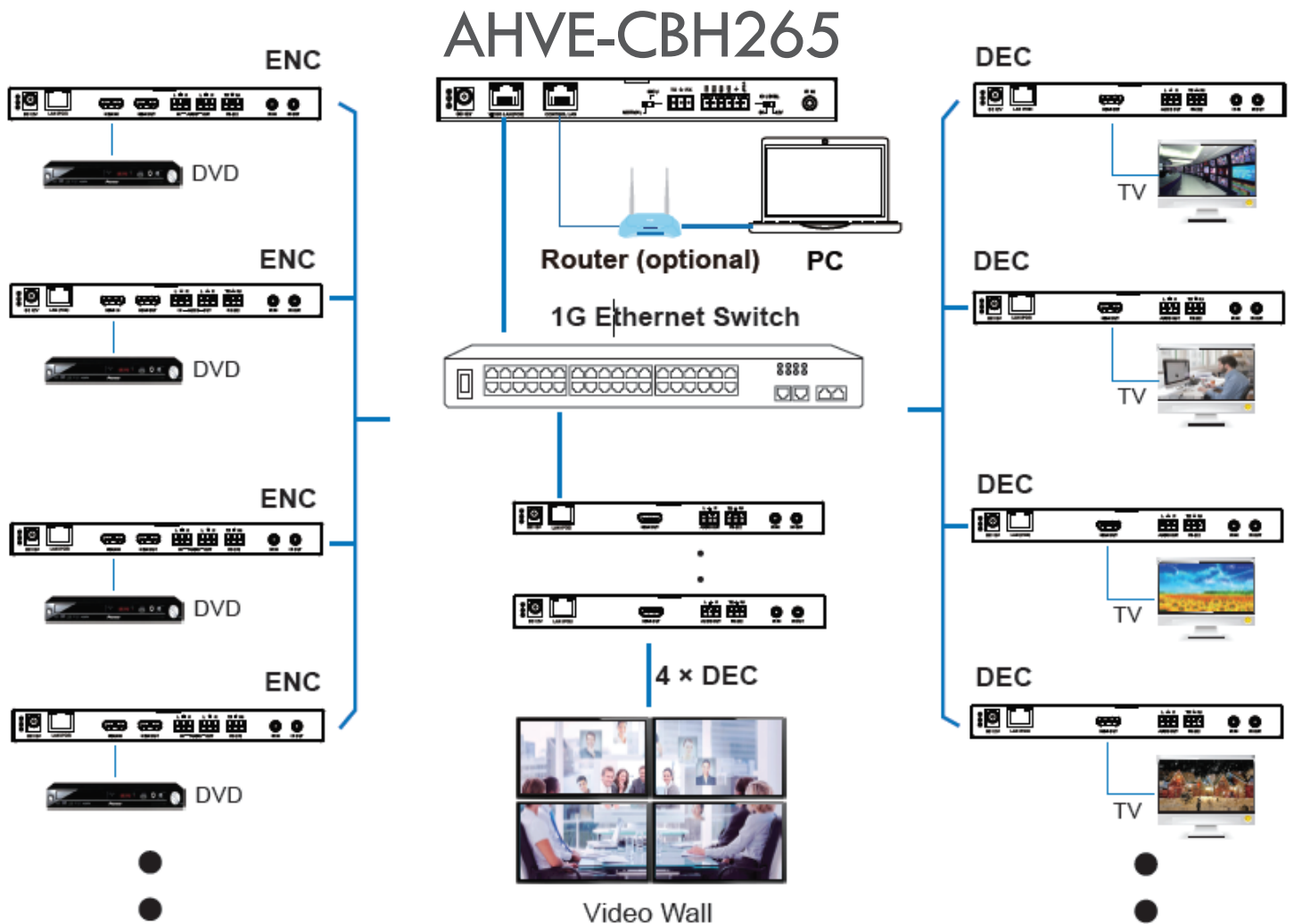

A network Switch used to set up the system should support below features:

1. Type of layer 3/managed network Switch.
2. Gigabit bandwidth.
3. Support multicast, and need to enable the multicast function.
4. Support IGMP snooping, and need to enable the IGMP snooping function.
5. Support filter/drop unregistered Multicast traffic, and need to enable the function.

The following Switch models are highly recommended.

Manufacturer	Model Number
HUAWEI	S5720S-28X-PWR-LI-AC
NETGEAR	S3300